

SETUP INSTRUCTIONS

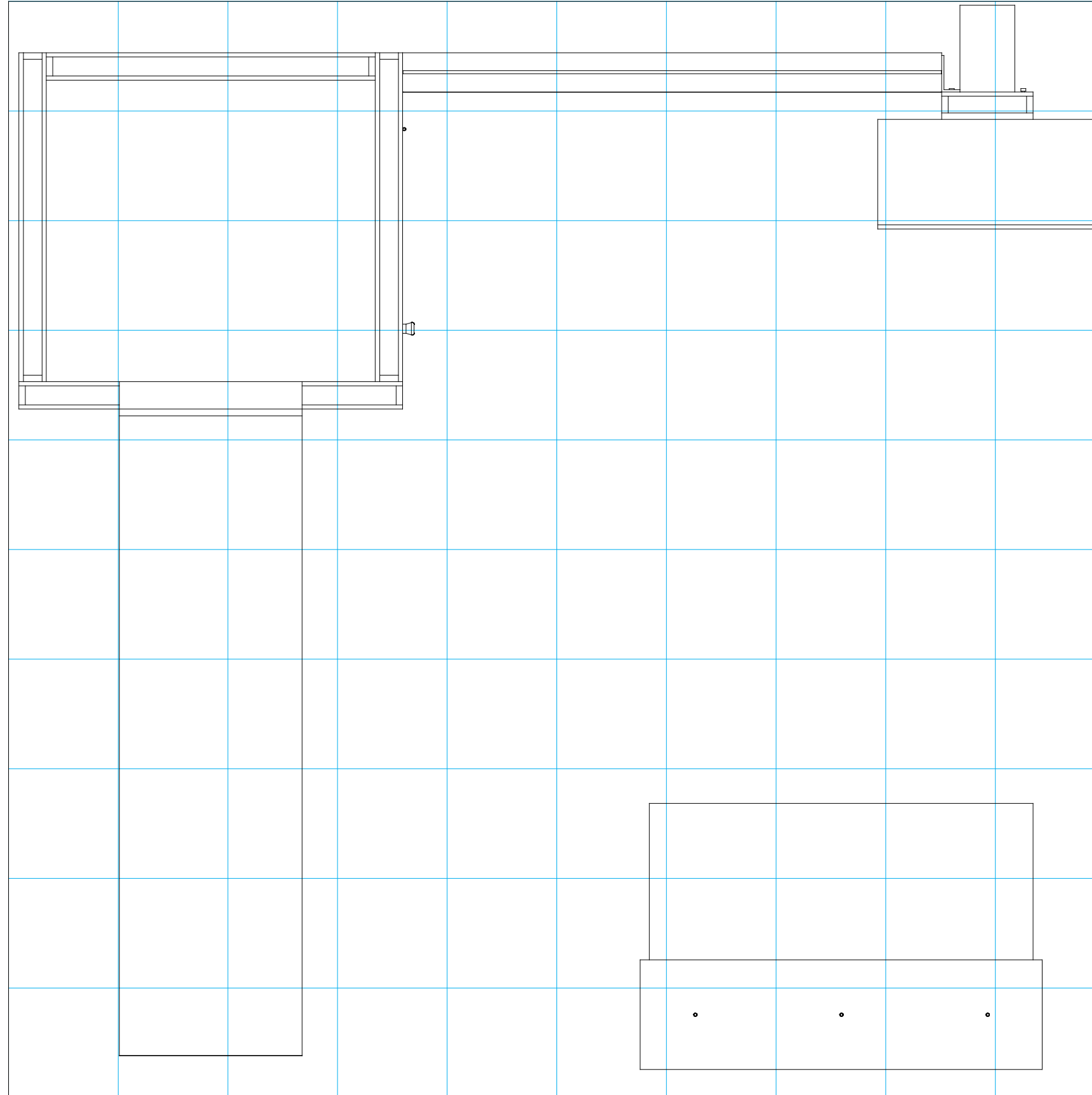

= 1 sq foot

General Setup Instructions

- Read entire setup instruction manual prior to unpacking parts and pieces.
- The setup instructions are created specifically for this configuration.
- Setup instructions are laid out sequentially in steps, including exploded views with detailed explanation for assembly.

Cleaning & Packing

- For Cleaning Metal, Plex, & Laminate Parts: Use a **MILD NON-ABRASIVE** cleanser and soft cloth/paper towel to clean all surfaces.
- Keep exhibit components away from heat and prolonged sun exposure. **Heat and UV exposure will warp and fade components.**
- Retain all provided Packing Materials. All provided packing materials are for ease of repacking & component protection.

Disassembly

- For loss prevention, tighten all set screws and locks during disassembly.

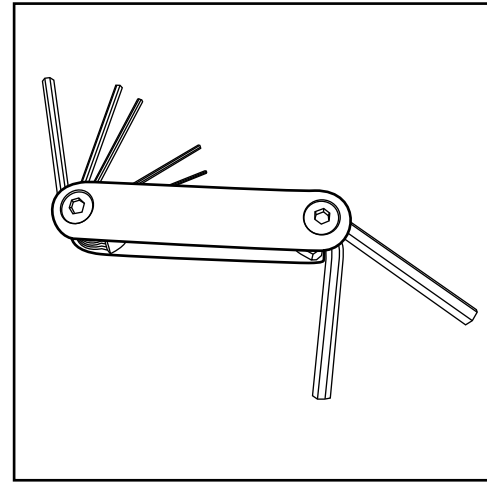

Hex Tool - Essential for Assembly

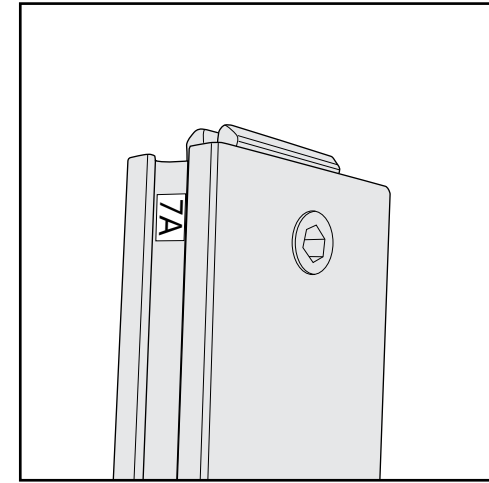

Part Identification - Numbering

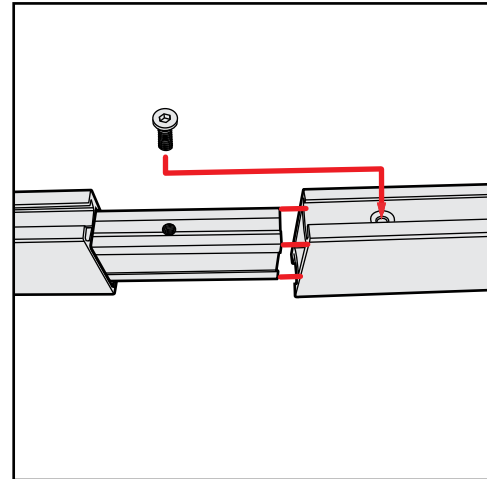

Spline Connection

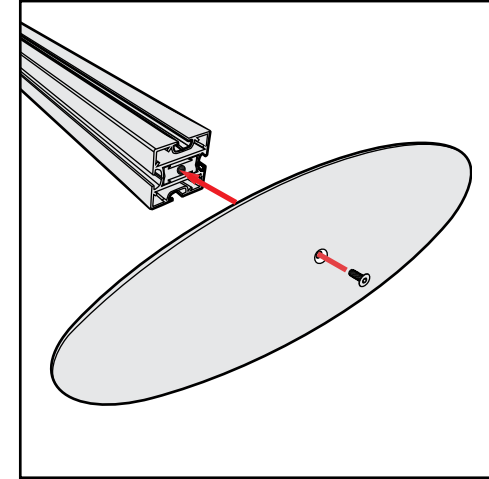

Base Plate & Extrusion Connection

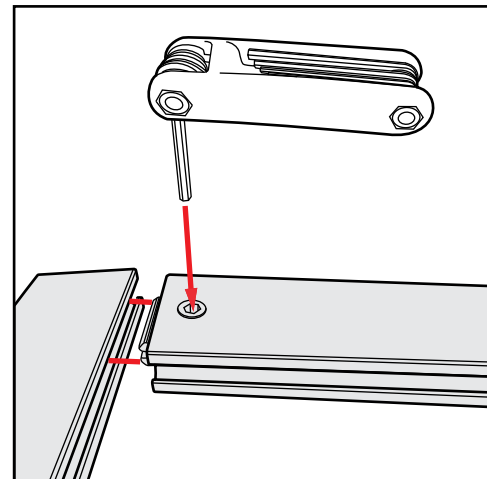

Extrusion & Lock Connection

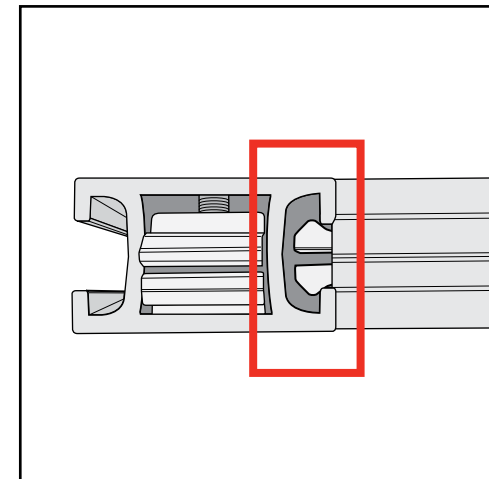

Engaged Lock



WARNING



DO NOT USE POWER TOOLS



LADDERS OR LIFTS MAY BE REQUIRED



ALL CONNECTIONS MUST BE TIGHTLY SECURED

Straight Connection

When assembling frame, first attach all **straight connectors**, then attach **corner connectors**.

- 1) Place extrusions end-to-end.
- 2) Loosen all knobs, then slide **straight connectors** across the seam of extrusions.
- 3) Tighten all knobs to secure connection.

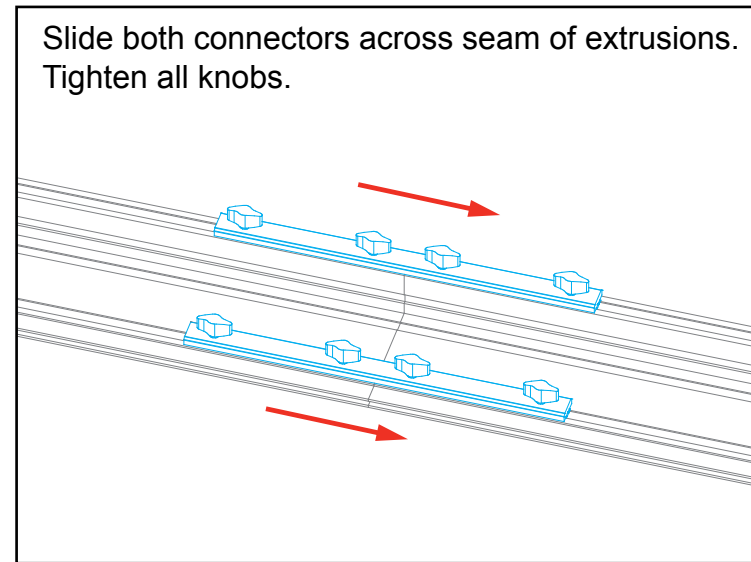
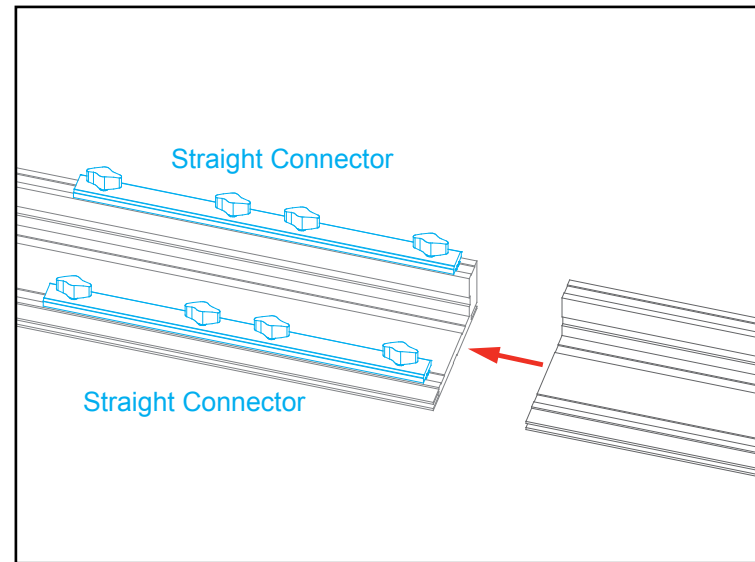

All knobs must be tightened securely to ensure a proper connection.

Disassembly

- 1) Loosen all knobs.
- 2) Slide connectors off of one extrusion.
- 3) Tighten knobs to prevent loss during packing & shipping.

Keep straight connectors in groove of extrusion. Do not remove connectors during disassembly.

Corner Connection

- 1) Loosen knobs, then slide vertical extrusions onto **corner connectors** of **lower** horizontal extrusion.
- 2) Slide **corner connectors** of **upper** horizontal extrusion into grooves of vertical extrusions.
- 3) Tighten all knobs to secure connection.

Disassembly

- 1) Loosen knobs on vertical extrusions.
- 2) Slide the vertical extrusions off of **corner connectors** on lower and upper horizontal extrusions.

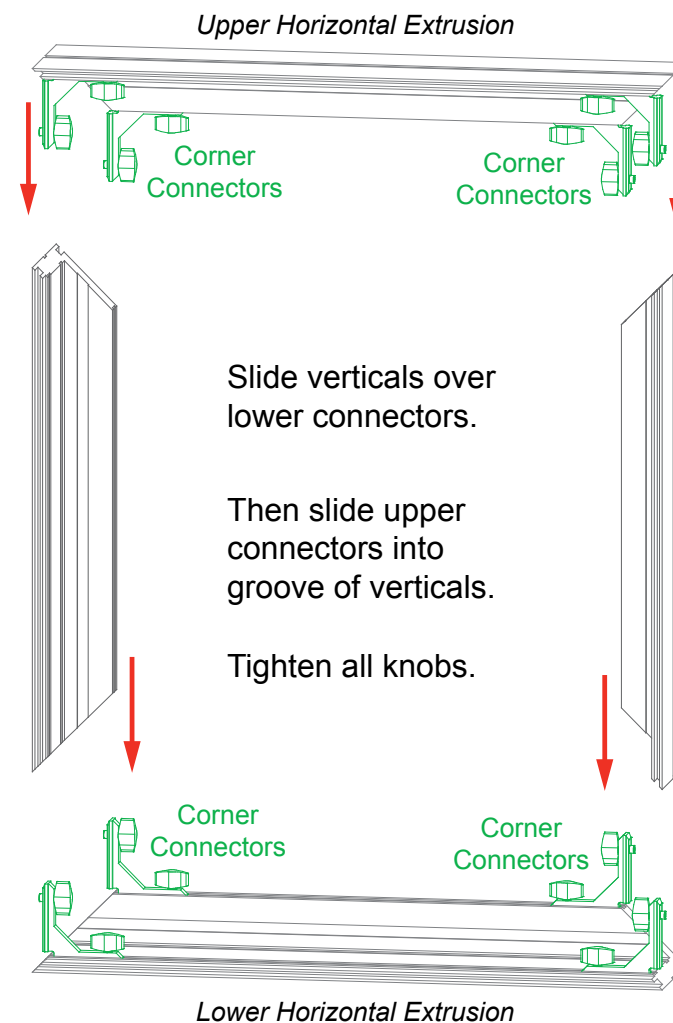

Adjust connectors if necessary to prevent gaps in connection.

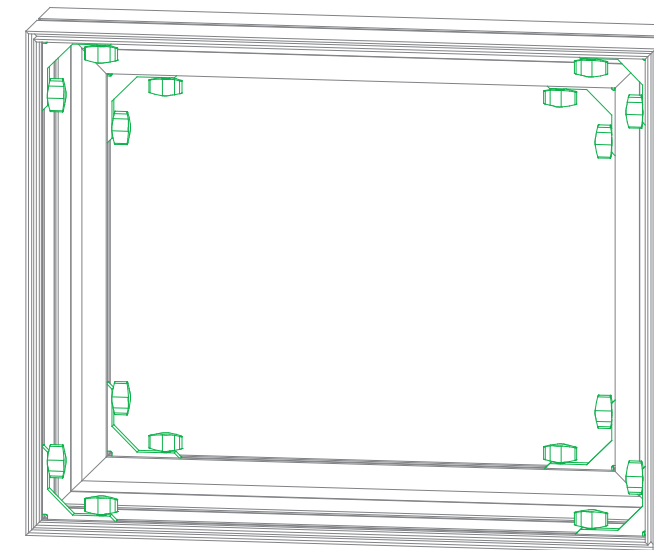

COMPLETED ASSEMBLY

All knobs must be tightened securely to ensure a proper connection.

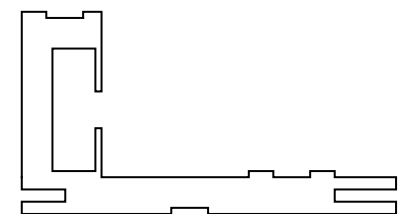

CEI110 Profile

The Perfect Fit

SEG Graphic Installation *in 3 Steps*

STEP 1: Attach Corners

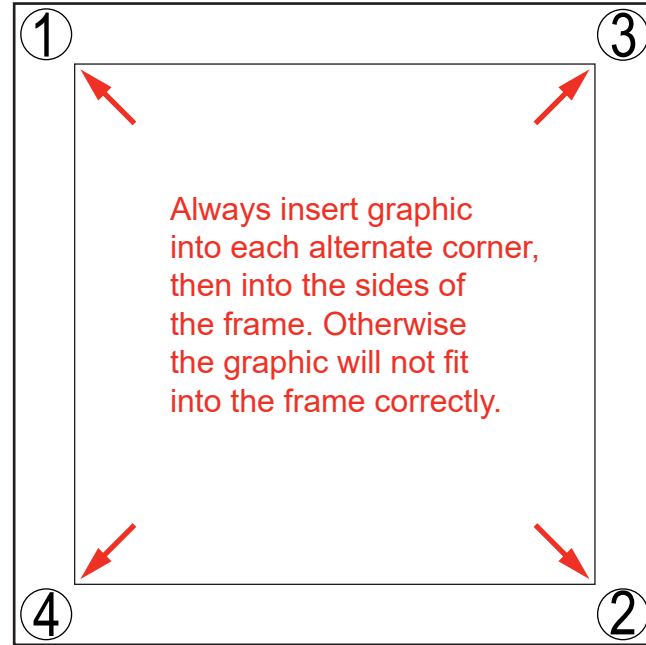

STEP 2: Attach Middle

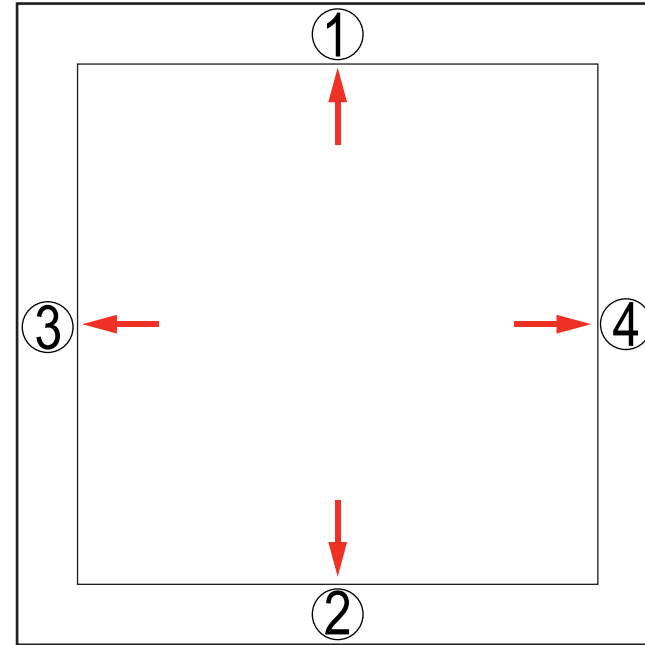

STEP 3: Attach Sides

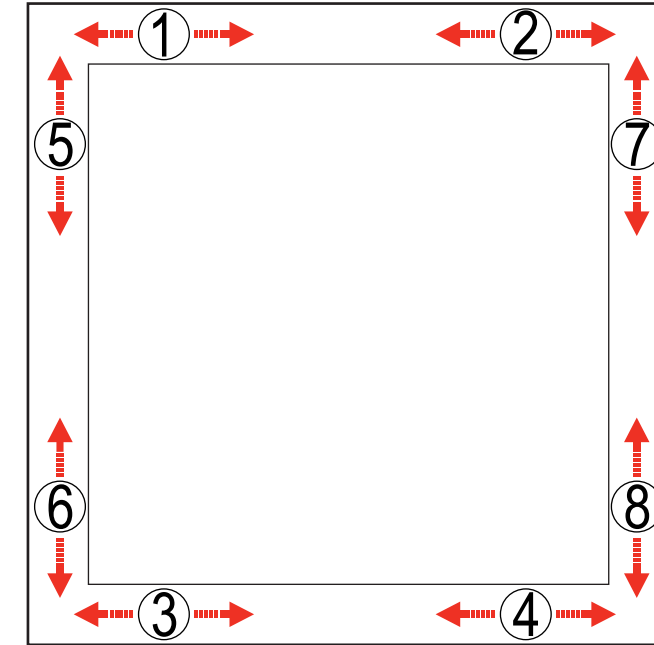

Insert narrow side of silicone welt into the channel at corner **1**, with fabric to the outside.
Repeat for opposite corner **2**, then corner **3**, then corner **4**.

Once corners are attached, press the middle of edge **1** into the channel. Then press middle of edge **2** into the channel on opposite side.
Repeat with edge **3** & **4**.

Once the middle of sides are attached, fully press the silicone welt into the channel, between center and corner at location **1**. Repeat the process between center and corner at location **2**.
Do the same for welt on opposite side, at locations **3** & **4**. Then repeat for locations **5** & **6** and **7** & **8**.



Once the welt is fully inserted on all sides, smooth out edges as needed for a perfect fit.

To remove the graphic from the frame, locate the fabric **pull tab**. Gently pull on the tab to remove the graphic.



Install video:



CRATE PACKING

Item	Qty.	Description
K1	1	36" w x 95" h x 3" d Back Panel
K2	1	36" w x 95" h x 3" d Side Panel
K3	1	36" w x 95" h x 3" d Side Panel w/ Door
K4	1	42" w x 95" h x 3" d Front Panel w/ accent

Steps:
 1) Assemble panels [K1-K2-K3-K4] together as shown, using roto cam locks. See **Roto Cam Lock Connection** detail.

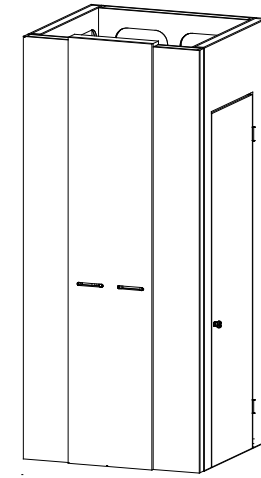

When assembled

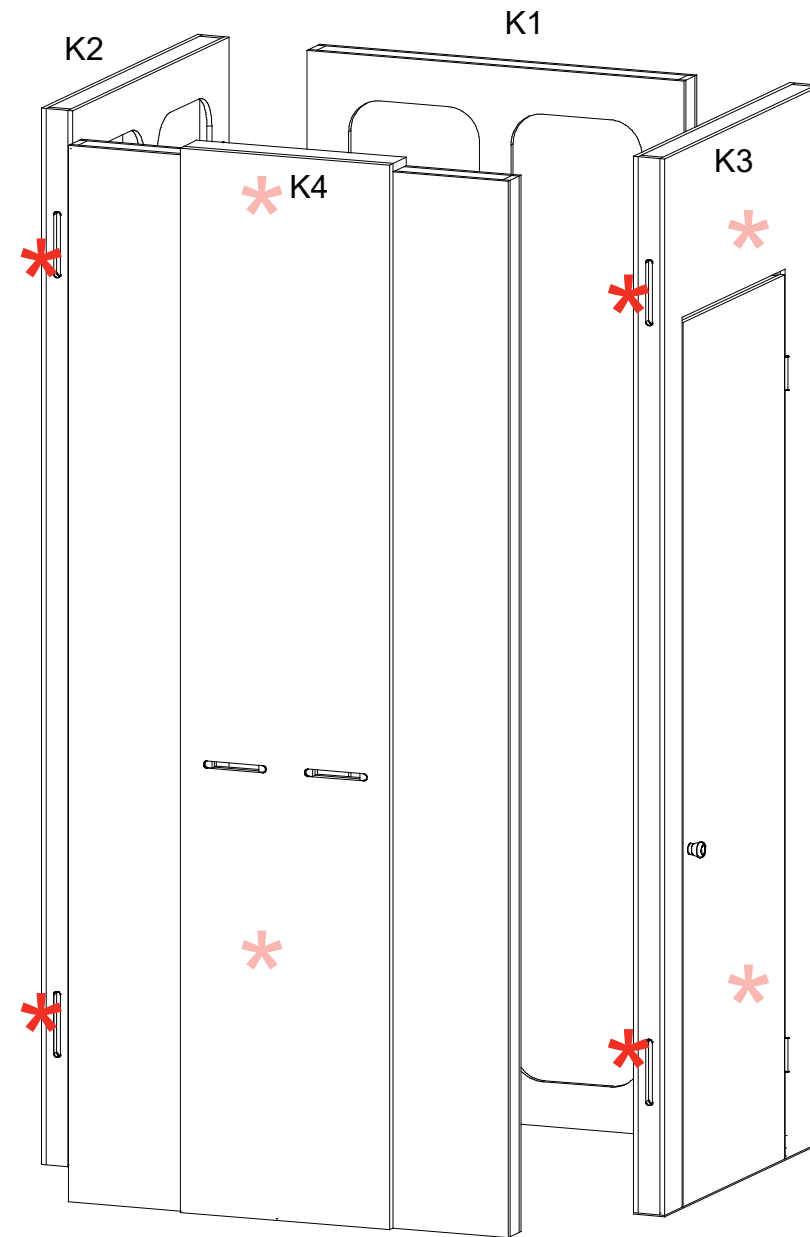

FRONT VIEW

* Roto Cam Lock Connection

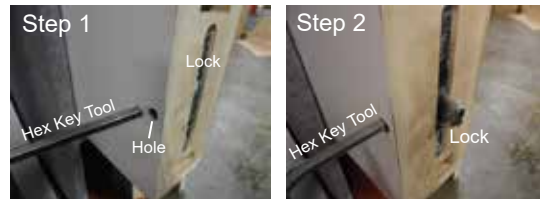

Place hex tool in hole on side of panel. Rotate to activate lock & secure panels together.

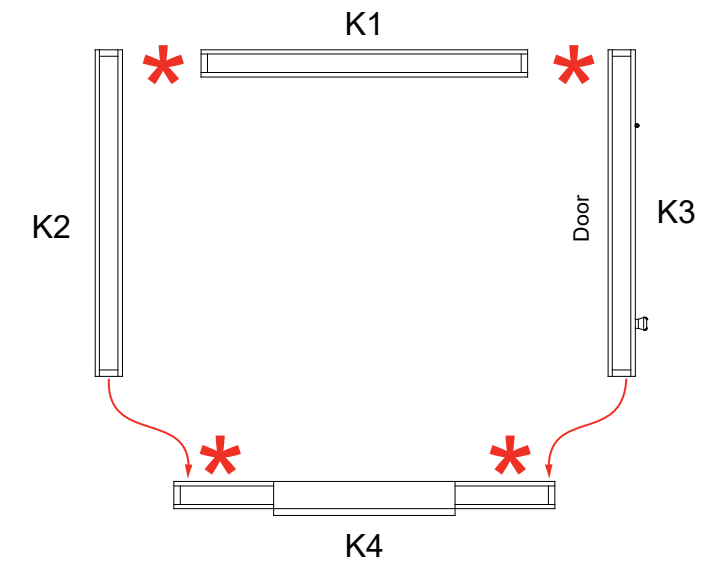

TOP VIEW

Item	Qty.	Description
D1	1	20"w x 70"l x 3"d Counter Top
D2	1	20"w x 39"h x 3"d Counter Leg

- Steps:
- 1) Connect Counter Top [D1] to Counter Leg [D2] using roto cam locks. See **Roto Cam Lock Connection** detail.
 - 2) Attach Counter Top [D1] to closet panel [K4] using **roto cam locks**.

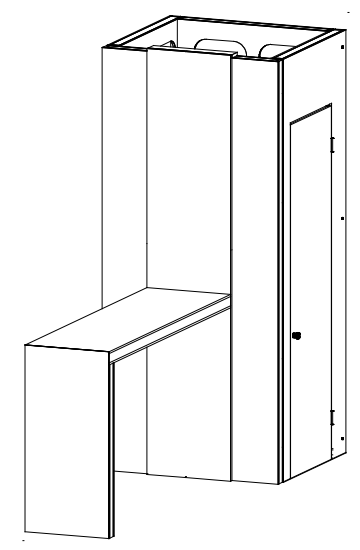

When assembled

*** Roto Cam Lock Connection**

Step 1

Hex Key Tool
Hole

Step 2

Hex Key Tool
Lock

Place hex tool in hole on side of panel. Rotate to activate lock & secure panels together.

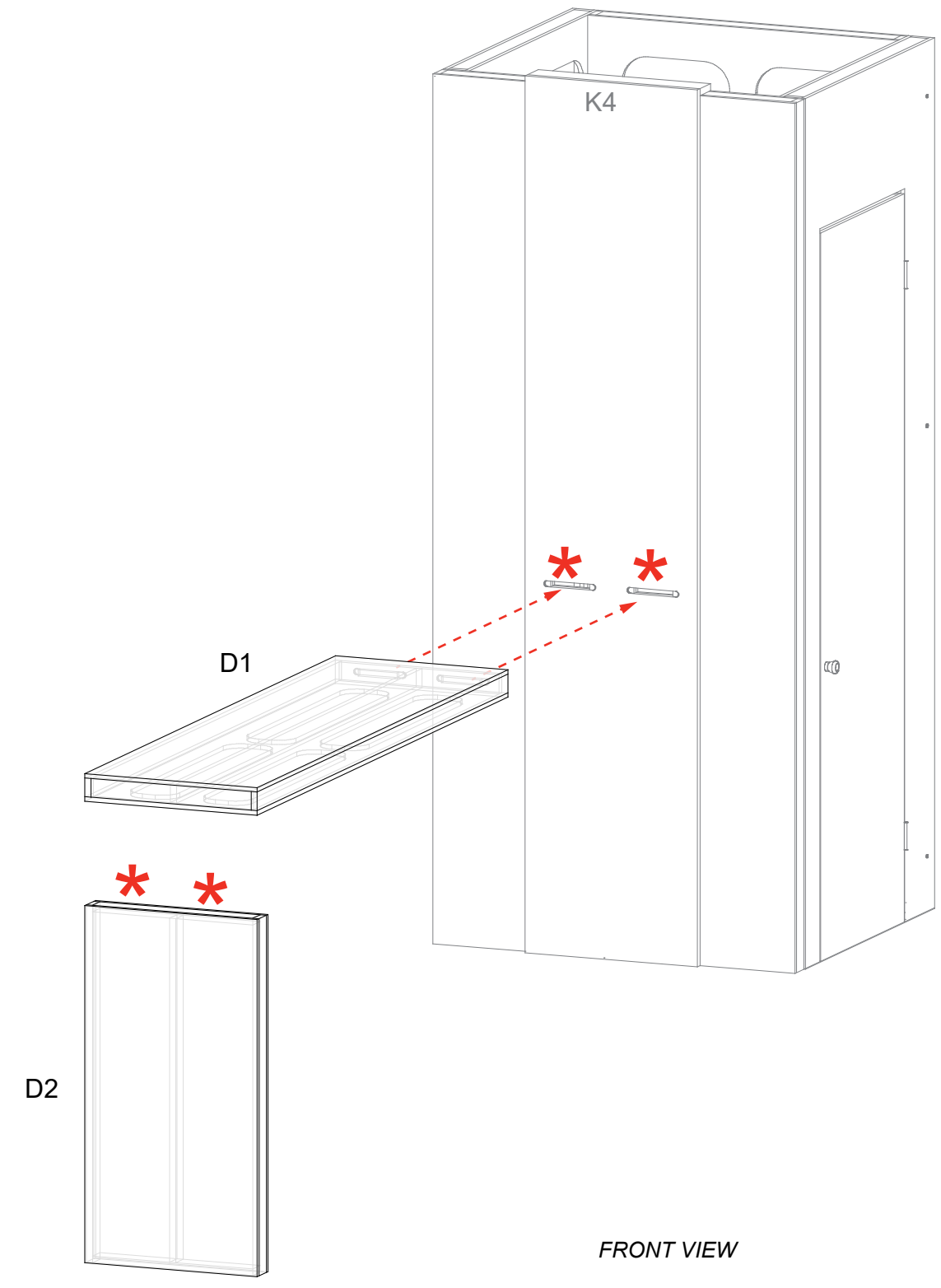

Item	Qty.	Description
1	1	95”h CEI110 Vertical Extrusion
2	1	95”h CEI110 Vertical Extrusion
3	1	59”w CEI110 Horizontal Extrusion
4	1	59”w CEI110 Horizontal Extrusion

Steps:

Refer to the CEI110 Frame Assembly general information page.

- 1) Assemble verticals [1,2] between horizontal [3,4] using **Corner Connectors**.
- 2) Connect power cords to Supernova lights as shown.

Assemble frame flat on ground.

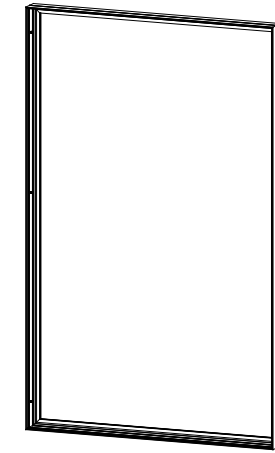
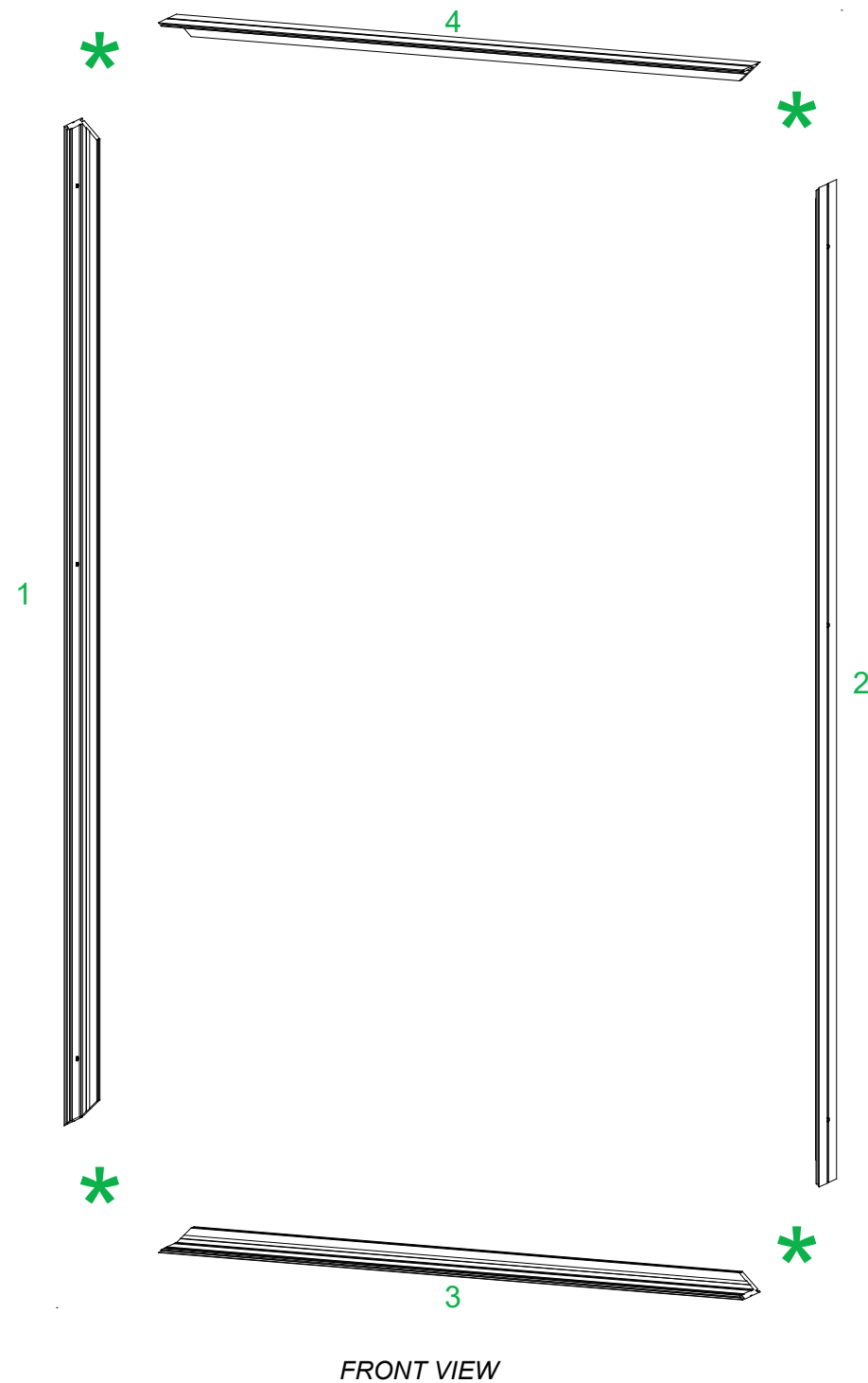
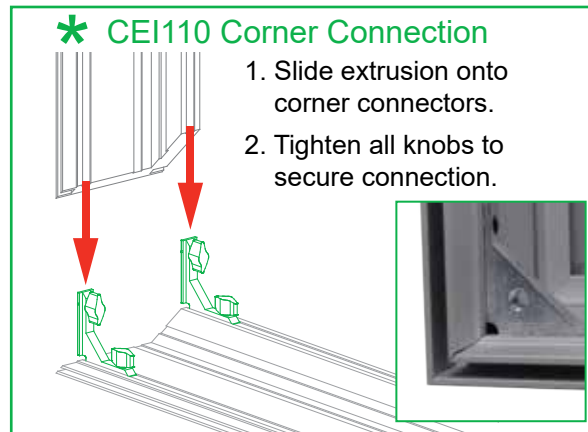

When assembled

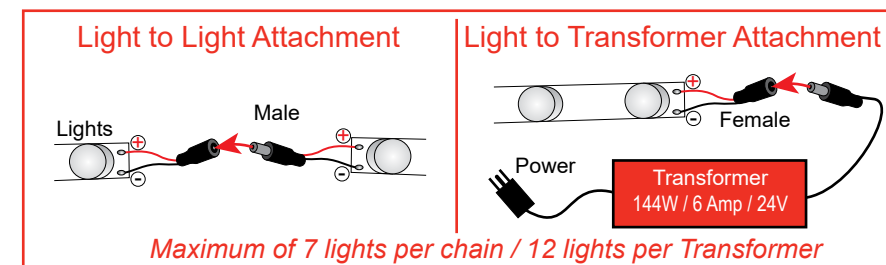
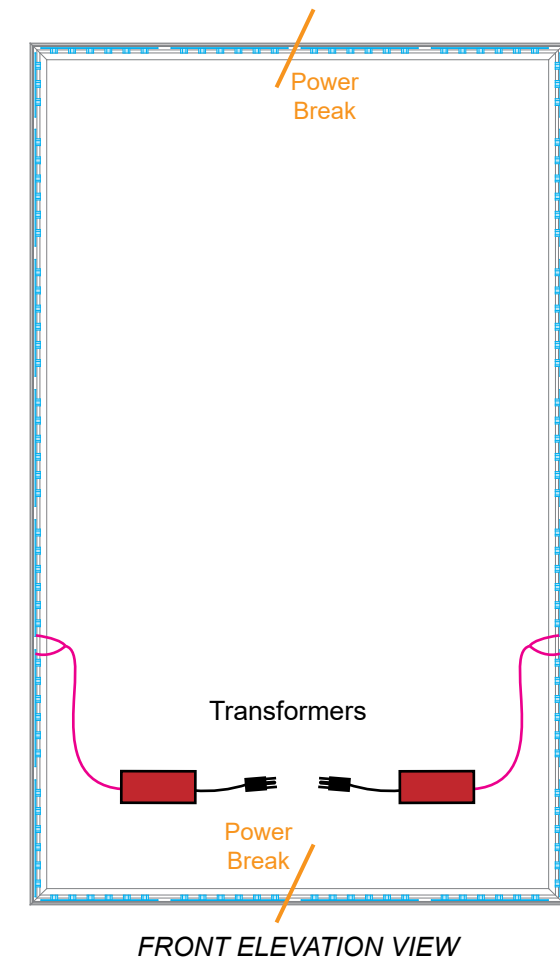

Steps:

- 1) Apply SEG graphic to front of lightbox assembly [1/2/3/4].
Refer to the SEG Installation general information page.
- 2) Connect lightbox vertical [2] to right closet panel [K3] using Bolt to T-Nut Connection.
- 3) Apply SEG Blocker to back of lightbox assembly.

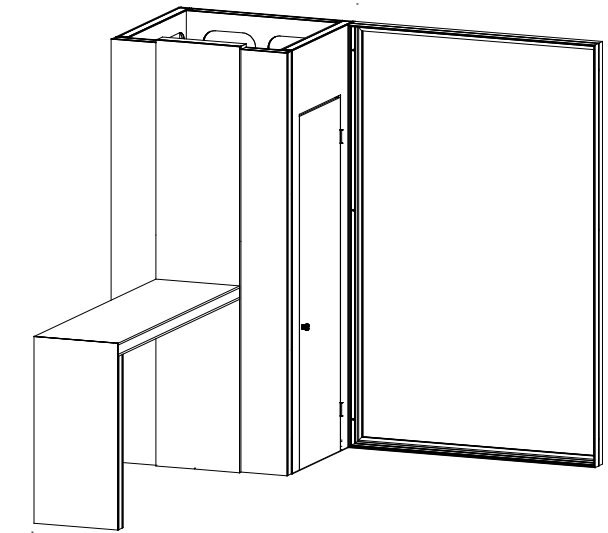

When assembled

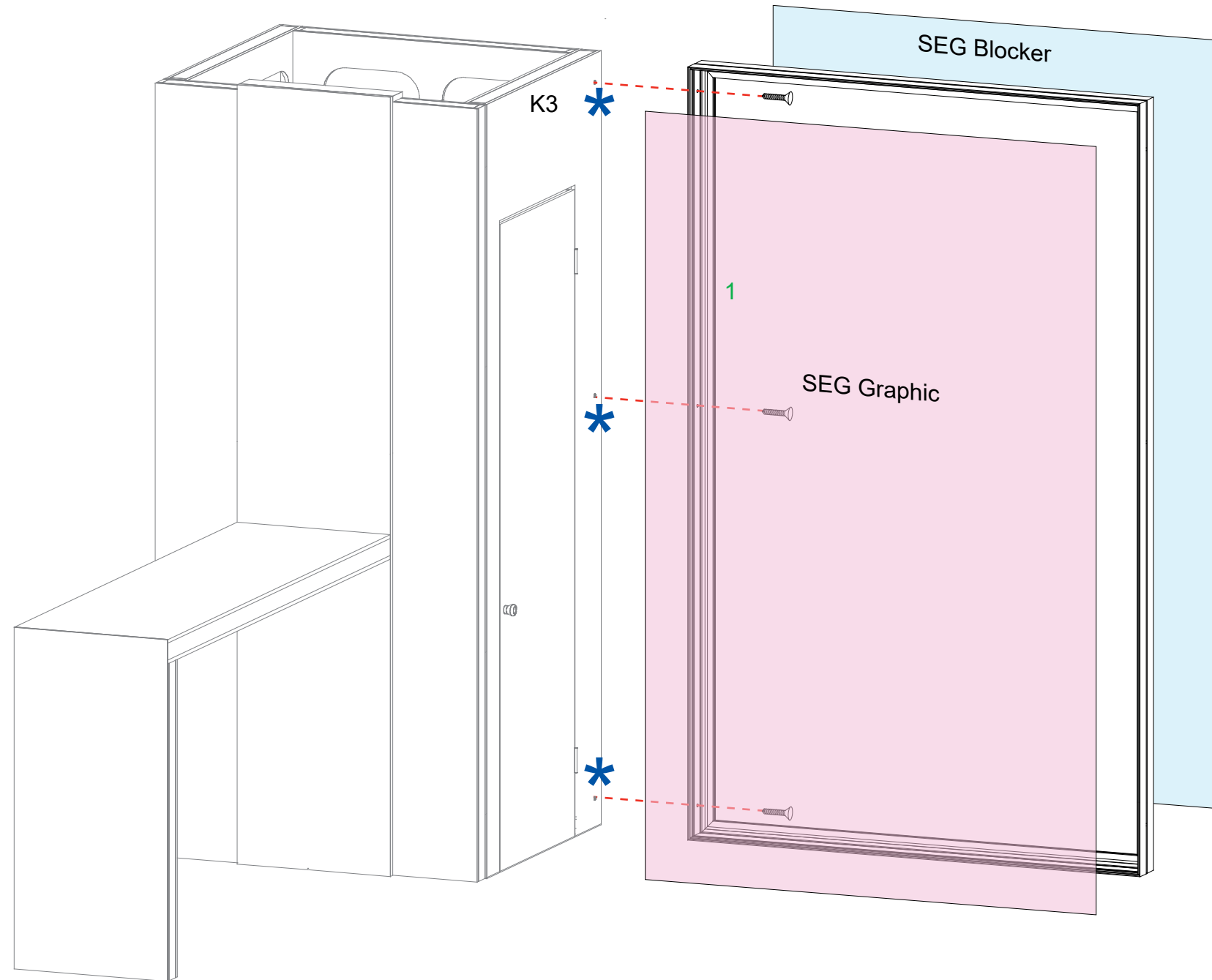
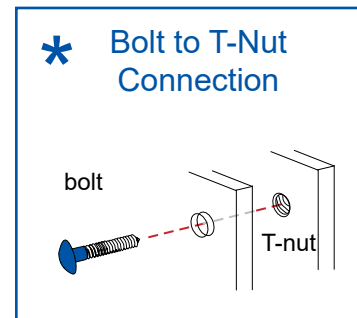

FRONT VIEW

Item	Qty.	Description
E	1	10"w x 95.71"h x 3"d Shelf Panel
5	1	6" x 22" SF61 Base Plate
F1-F5	5	24"w x 12"d Shelf w/ Z33
--	3	4" x 2" x 2" custom L-Bracket

Steps:

- 1) Connect Base Plate [5] to bottom of Panel [E], using bolts.
- 2) Attach Shelves [F1,F2,F3,F4,F5] to front of Panel [E].
See **Shelf Attachment** detail. Run power cords for LED lights through wire management holes to power source.
- 3) Attach lightbox vertical [2] to Panel [E] using brackets.
See **Bracket Attachment** detail.

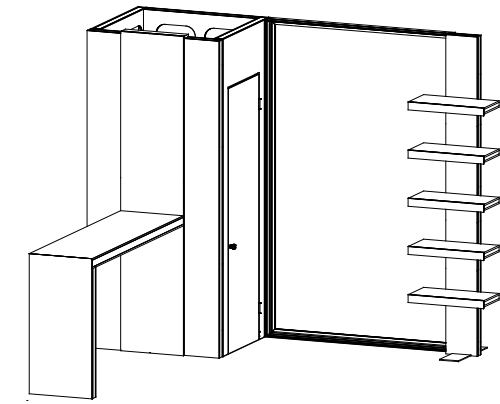

When assembled

* Shelf Attachment

Insert horizontal extrusions of shelf into slots on wall panel. Secure using bolts on back side of panel.

Feed power cord for LED lights through wire management hole & connect to power source.

BACK VIEW

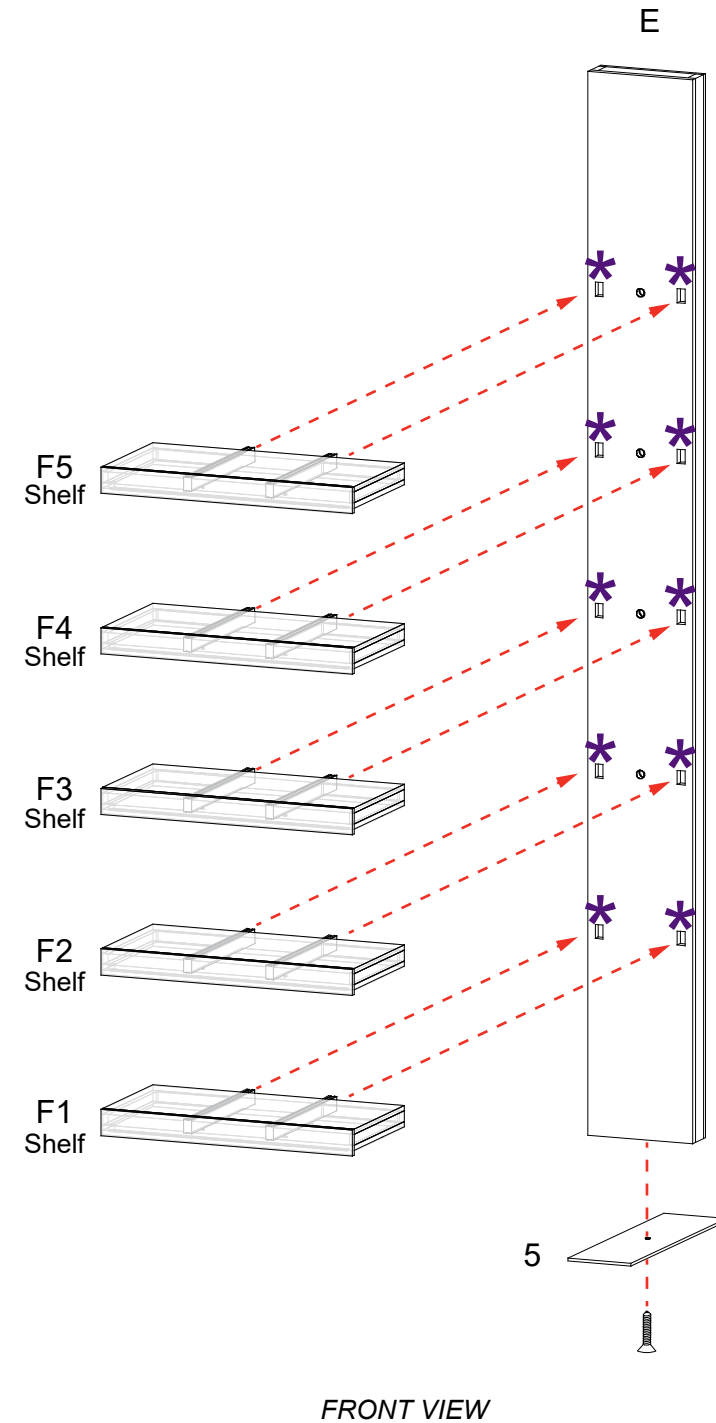

* Bracket Attachment

Attach bracket to back of wall panel using Bolt to T-Nut connection.

Slide V4 connector into groove of vertical extrusion; tighten set screw to secure V4 in place.

BACK VIEW

Attach bracket to vertical extrusion using bolt.

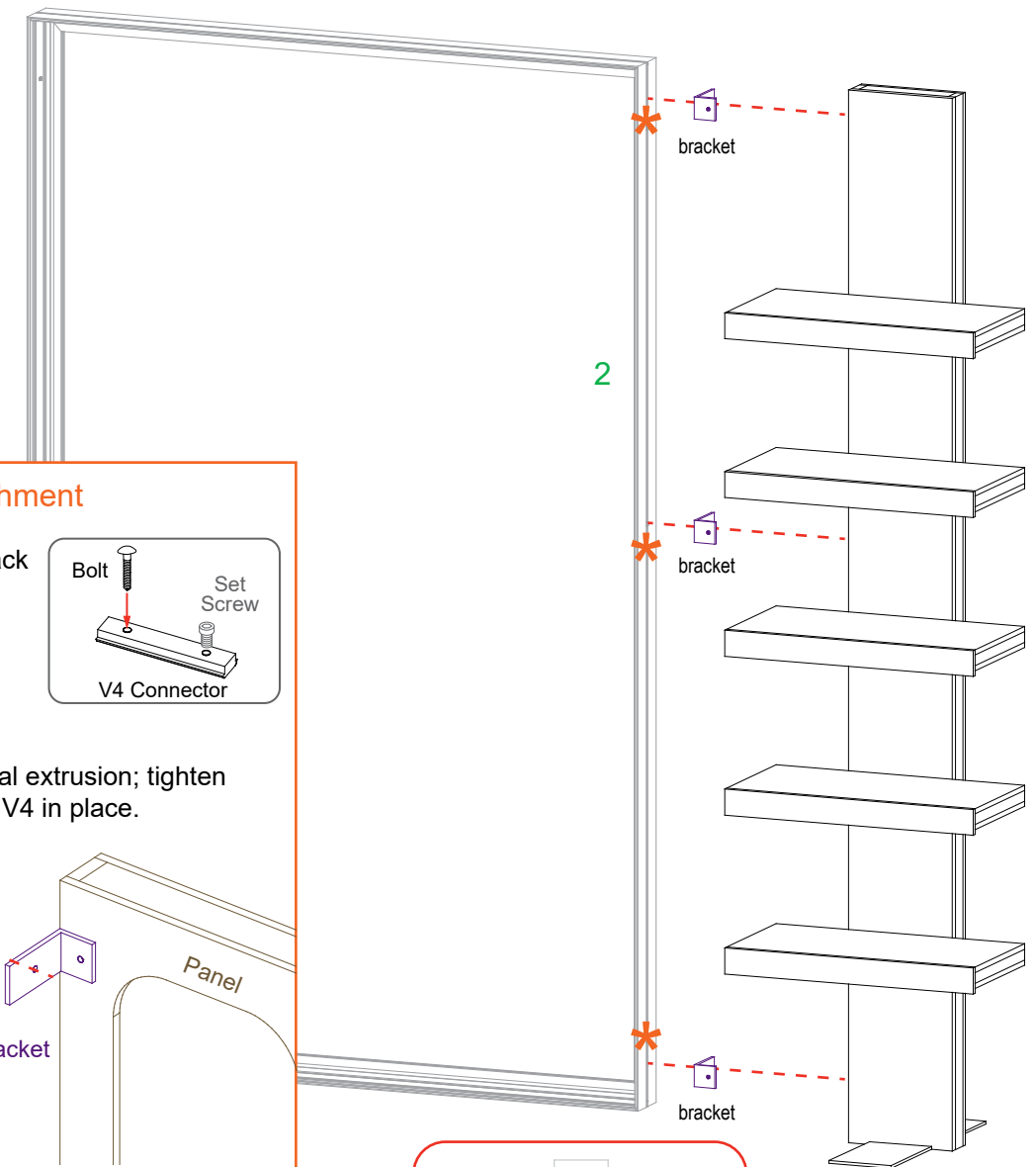

LED Power Cord Attachment

Connect transformer to LED Controller. Then connect transformer to power source.

LED Lights

LED Controller

Transformer 48W / 2 Amp / 24V

Steps:

- 1) Connect power cords to Supernova lights as shown.
- 2) Apply SEG graphic to front of lightbox. Refer to the SEG Installation general information page.

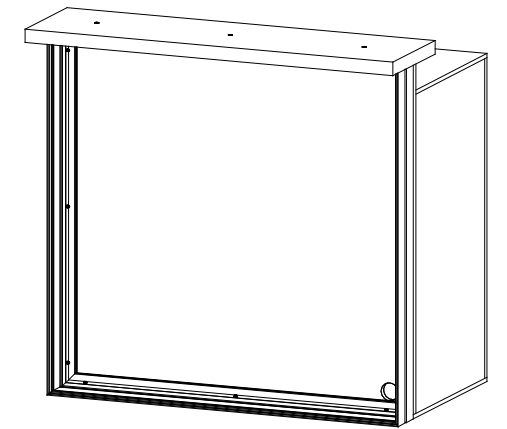
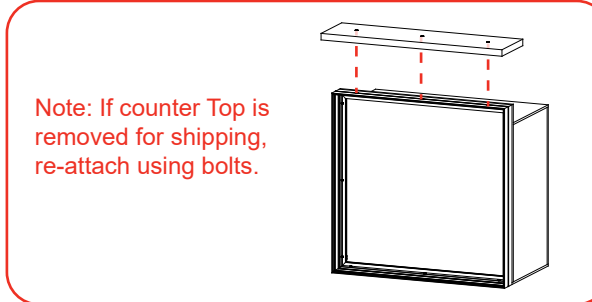
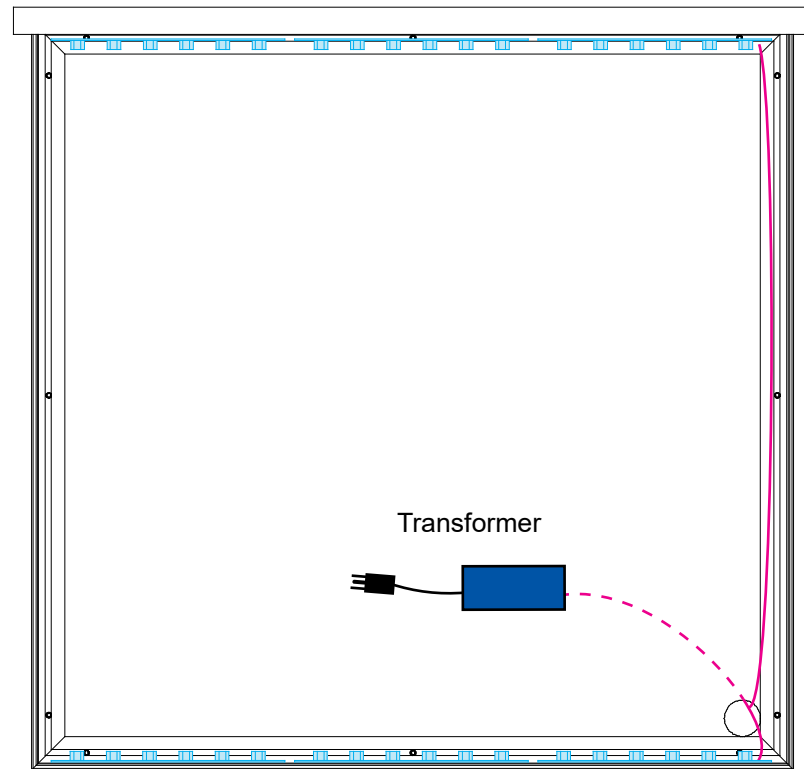

When assembled

